

三菱工業用ミシン部品カタログ

MITSUBISHI Industrial Sewing Machine Parts Catalog

Model DY-330

目次	INDEX	Page
1. 本体関係	Arm bed & its accessories	2
2. 天秤上軸関係	Thread take-up lever & arm shaft mechanism	4
3. 縦軸針棒関係	Vertical shaft & needle bar mechanism	6
4. 縫目調節関係	Stitch length regulator mechanism	8
5. 押工関係	Presser foot mechanism	10
6. 上部送り関係	Upper feed mechanism	12
7. 送り関係	Lower feed mechanism	16
8. 下軸カマ関係	Hook shaft & rotating hook mechanism	18
9. 給油関係	Oil lubrication mechanism	20
10. 付属品箱関係	Accessory box & accessories	22
11. 付属品関係	Oil pan & other accessories	24

From the library of: Diamond Needle Corp

本体関係

ARM BED & ITS ACCESSORIES

DY-330

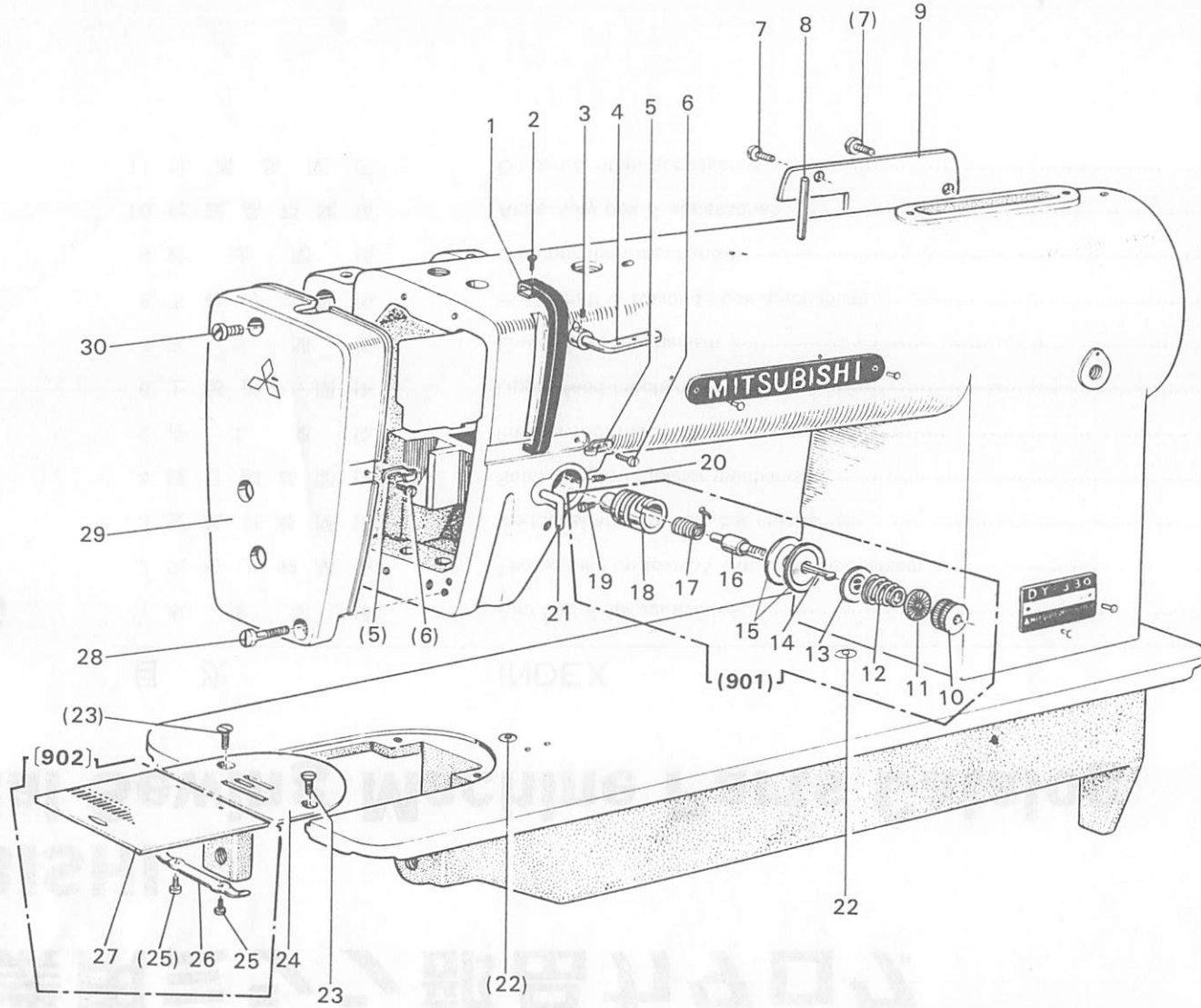

From the library of: Diamond Needle Corp

本体関係

ARM BED & ITS ACCESSORIES

Fig. No.	部品コード Parts. No.	資材コード Ref.No.	部 品 名	Description	使用 個数 Amt. Req.	共通部品 Common Parts										
						DY330-12	DY330-22									
1	MF 10A0 584	W468291H01	天 秤 カ バ ー	Thread take-up cover	1	○										
	MF 17B0 584	W458150H01	天 秤 カ バ ー	Thread take-up cover	1	○										
2	M9 1107 002	W500092H01	平 ネ ジ 11/64(40)×5.5	Screw 11/64(40)×5.5	1	○										
3	M9 1108 001	B 503846H01	頭ナシ止メネジ 11/64(40)×5.5	Set screw 11/64(40)×5.5	1	○										
4	MF 10A0 180	B 409034H01	三ツ目糸カケ	Three hole thread guide	1	○										
	MF 10A0 181	W452151H01	糸 カ ケ (アーム)(面板)	Thread guide for arm with face plate	2	②	①									
5	MF 17B0 181	W470968H01	糸 カ ケ (アーム)	Thread guide for arm	1		①									
	M9 0909 003	W501901H01	丸 平 ネ ジ 9/64(40)×6	Screw 9/64(40)×6	2											
7	M9 0915 003	W502952H01	丸 平 ネ ジ 9/64(40)×6	Screw 9/64(40)×6	2											
8	MF 10A0 186	W461744H01	糸 立 棒	Spool pin	1											
9	MG 30B0 880	W461086H01	横 蓋	Arm side cover	1											
10	M9 1608 046	W476469H01	調 子 ナ ッ ト	Thread tension regurating thumb nut	1	○										
11	MT 60A0 802	W476470H01	回 り 止 メ	Thumb nut revolution stopper	1	○										
12	MF 43C0 245	W478173H01	糸 調 子 バ ネ	Thread tension spring	1	○										
13	MM 11A0 556	W477611H01	調 子 皿 押 エ	Thread tension releasing disc	1	○										
14	M9 0204 060	B 509216H01	ピ ン φ2×28.4	Thread tension releasing pin	1	○										
15	MF 10A0 555	W444059H01	調 子 皿	Thread tension disc	2	○										
16	MF 10A0 553	B 419178H01	調 子 棒	Thread tension stud	1	○										
17	MF 12B0 187	W461748H01	糸 取 り バ ネ	Thread take-up spring	1	○										
		W453140H01	バネ止メブッシュ	Thread tension regulator bushing	1	○										
19	M9 0901 002	W500741H01	平 ネ ジ 9/64(40)×4	Screw 9/64(40)×4	1	○										
20	M9 1508 001	B 509088H01	頭ナシ止メネジ 15/ 64(28)×8	Set screw 15/64(28)×8	1	○										
901	MF 43E0 210	W331008G03	上 糸 調 節 器 (組)	Thread tension regulator complete	1	○										
21	MG 30B0 216	W481679H01	上 糸 案 内	Thread guide	1	○										
22	MN 10A4 742	W462905H01	蓋 (オイルカップ)	Oiler cap	2	○										
23	M9 1106 011	W502948H01	丸 皿 ネ ジ 11/64(40)×8	Screw 11/64(40)×8	2	○										
24	MF 26B0 101	W322721H01	針 板 B2.6 (7mm)	Needle plate B2.6 (7mm)	1	○										
25	M9 0604 002	B 509070H01	平 ネ ジ 3/32(56)×2.2	Screw 3/32(56)×2.2	2	○										
26	MF 10A0 471	B 419207H01	スベリ板バネ	Spring for slide plate	1	○										
27	MF 10A0 470	B 419208H01	スベリ板	Slide plate	1	○										
902	MF 10E0 470	W461757G01	スベリ板(組)	Slide plate complete	1	○	○									
28	M9 1106 003	W500369H01	丸 平 ネ ジ 11/64(40)×20	Screw 11/64(40)×20	1	○										
29	MG 30B0 830	W324576H04	面 板	Face plate	1	○										
30	M9 1070 003	S 516131H01	丸 平 ネ ジ 4×30	Screw 4×30	1	○										

From the library of Diamond Needle Corp.

天秤・上軸関係

THREAD TAKE-UP LEVER & ARM SHAFT MECHANISM

DY-330

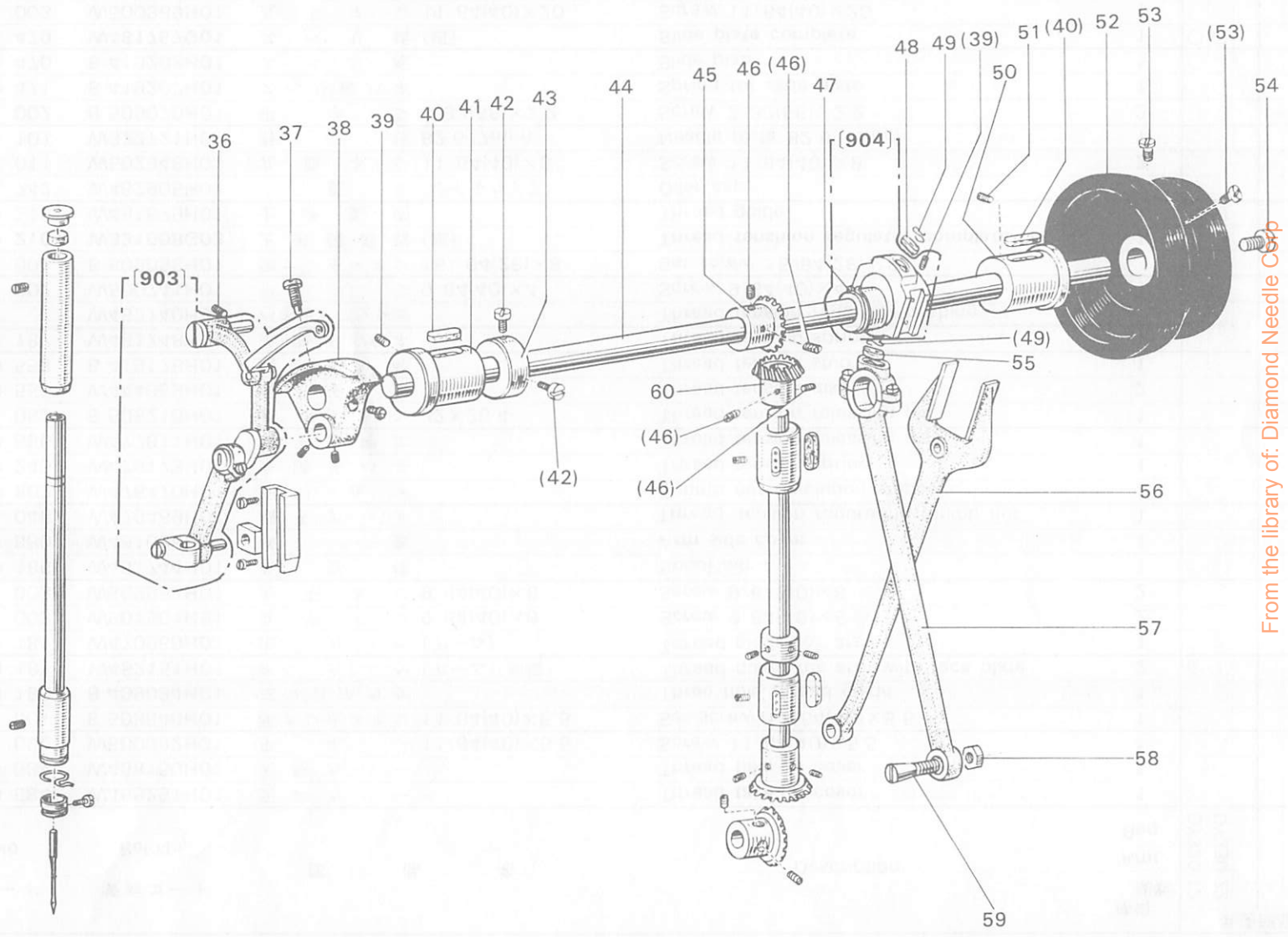

From the library of: Diamond Needle Corp

天秤・上軸関係

THREAD TAKE-UP LEVER & ARM SHAFT MECHANISM

Fig.	部品コード Parts No.	資材コード Ref.No.	部 品 名	Description	使用 個数 Amt. Req.	共通部品 Common Parts														
						DY330-12	DY330-22													
903	MF 62E0 580	W331012G01	天 秤 針 ク (組)	Thread take-up lever & needle bar complete	1	○														
	MF 67E0 580	W331012G02	天 秤 針 ク (組)	Thread take-up lever & needle bar complete	1		○													
36	M9 1519 001	B 509114H01	頭ナシ止メネジ 15/64(28)×23.5	Set screw 15/64(28)×23.5	1	○	○													
37	M9 1802 006	B 503851H01	棒 先 平 ネ ジ 9/32(28)×14	Screw 9/32(28)×14	1	○	○													
38	MF 60A1 383	W450075H03	ク ラ ン ク	Crank	1	○	○													
39	M9 1508 001	B 509088H01	頭ナシ止メネジ 15/64(28)×8	Set screw 15/64(28)×8	3	○	○													
40	MF 60A2 740	W501524H01	フ ェ ル ト	Felt for arm shaft bushing	2	○	○													
41	MF 60A0 232	W464011H01	上 軸 メ タ ル (左)	Arm shaft bushing (left)	1	○	○													
42	M9 1501 002	W502945H01	平 ネ ジ 15/64(28)×8.5	Screw 15/64(28)×8.5	2	○	○													
43	MG 41B0 352	W470213H01	カ ラ ー	Arm shaft collar	1	○	○													
44	MF 60A0 230	W326240H01	上 軸	Arm shaft	1	○	○													
45	MF 40A0 331	P 611003X02	傘 歯 車 (上軸)	Bevel gear for arm shaft	1	○	○													
46	M9 1606 001	P 911000X01	頭ナシ止メネジ 1/4(40)×7	Set screw 1/4(40)×7	4	○	○													
47	M9 0320 065	S 591411H02	C 形 止 メ 輪	C-type stop ring	1	○	○													
904	MF 70E0 280	W481451G01	送 り カ ム (組)	Feed cam complete	1	○	○													
48	MF 60A1 740	W500738H01	フ ェ ル ト	Felt for Feed cam	1	○	○													
49	MF 60A0 700	W500836H01	バ ネ	Spring for Feed cam	2	○	○													
50	MF 60A0 233	W451575H01	上 軸 メ タ ル (右)	Arm shaft bushing (right)	1	○	○													
51	M9 1513 001	B 509060H01	頭ナシ止メネジ 15/64(28)×11	Set screw 15/64(28)×11	1	○	○													
52	MF 10A0 682	W453500H01	ハ ズ ミ 車	Balance wheel	1	○	○													
	MG 37B1 682	W231701H01	ハ ズ ミ 車	Balance wheel	1	○	○													
53	M9 1502 002	W500509H01	平 ネ ジ 15/64(28)×12	Screw 15/64(28)×12	2	○	○													
54	M9 2201 003	W461726H01	丸 平 ネ ジ 11/32(28)×10	Screw 11/32(28)×10	1	○	○													
55	MG 30B0 740	W464014H01	フ ェ ル ト	Felt for crank rod	1	○	○													
56	MF 65B0 744	W324562H01	フ タ 又	Feed forked	1	○	○													
57	MF 60A0 384	W321787H01	ク ラ ン ク ロ ッ ト	Crank rod	1	○	○													
58	M9 1802 045	B 508961H01	ナ ッ ト 9/32(28)	Nut 9/32(28)	1	○	○													
59	M9 1806 036	W469444H01	テ ー パ ー 頭 ネ ジ 9/32(28)×23	Taper screw 9/32(28)×23	1	○	○													
60	MF 60A0 333	P 611004X01	傘 歯 車 (堅上)	Bevel gear for vertical shaft (upper)	1	○														
	MF 40A0 333	P 611000X02	傘 歯 車 (堅上)	Bevel gear for vertical shaft (upper)	1		○													

From the library of Diamond Needle Corp.

豎軸・針棒關係

VERTICAL SHAFT & NEEDLE BAR MECHANISM

DA-330

DY-330

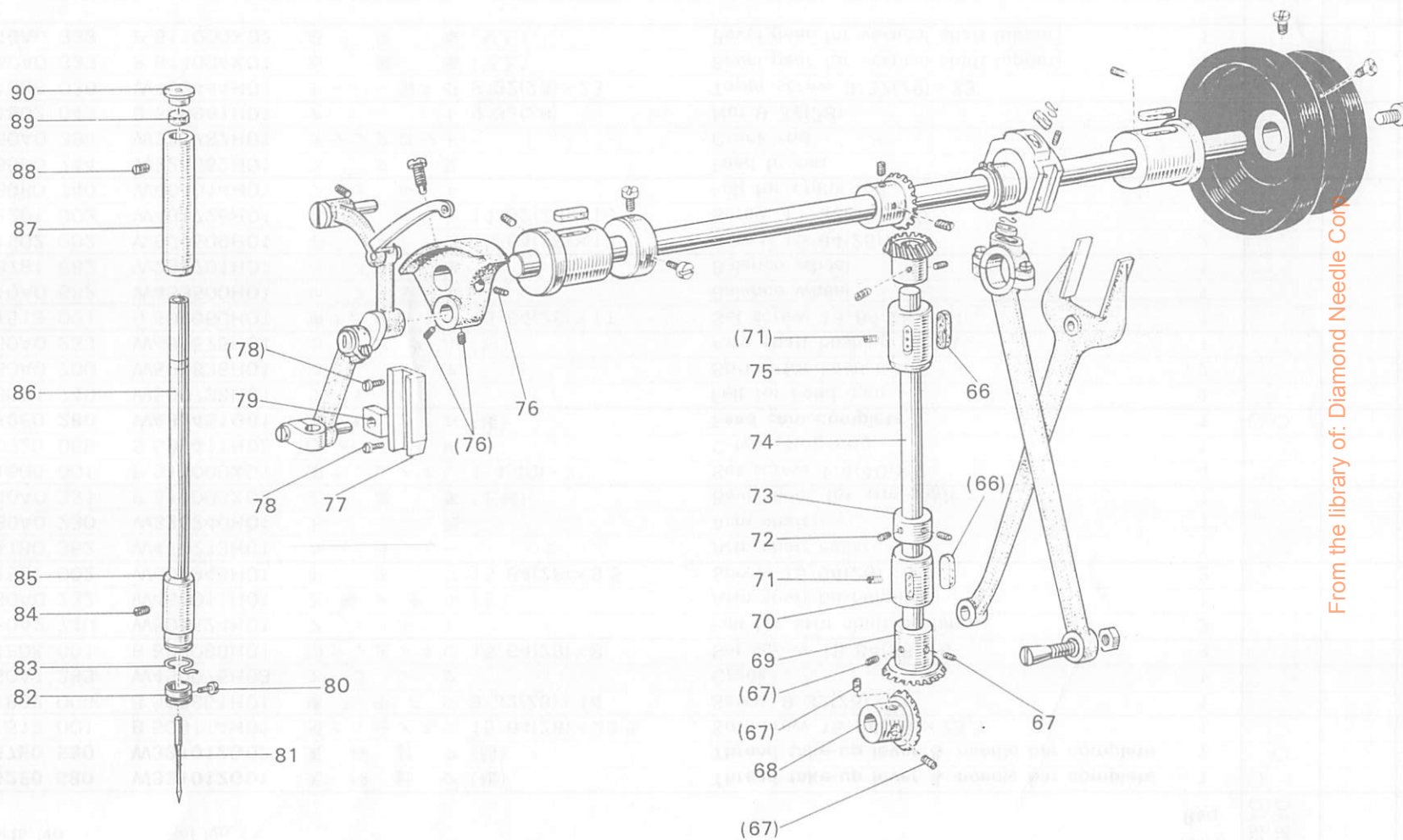

From the library of: Diamond Needle Corp

豎軸・針棒関係

VERTICAL SHAFT & NEEDLE BAR MECHANISM

Fig. No.	部品コード Parts No.	資材コード Ref.No.	部 品 名	Description	使用 個数 Amt. Req.	共通部品 Common Parts														
						DY330-12	DY330-22													
66	MF 60A0 740	W500042H01	フェルト	Felt for vertical shaft bushing	2	○	○													
67	M9 1606 001	P 911000X01	頭ナシ止メネジ 1/4(40)×7	Set screw 1/4(40)×7	4	○	○													
68	MF 60A0 332	P 611006X01	傘 歯 車 (下軸)	Bevel gear for hook shaft	1	○														
	MF 40A0 332	P 611002X02	傘 歯 車 (下軸)	Bevel gear for hook shaft	1		○													
69	MF 60A0 334	P 611005X01	傘 歯 車 (豎下)	Bevel gear for vertical shaft (under)	1	○														
	MF 40A0 334	P 611001X02	傘 歯 車 (豎下)	Bevel gear for vertical shaft (under)	1		○													
70	MF 60A0 522	W451300H01	豎 軸 メ タ ル (下)	Vertical shaft bushing (under)	1	○														
	MF 67B0 522	W462734H01	豎 軸 メ タ ル (下)	Vertical shaft bushing (under)	1		○													
71	M9 1513 001	B 509060H01	頭ナシ止メネジ 15/64(28)×10	Set screw 15/64(28)×10	2	○	○													
72	M9 1503 001	B 508971H01	頭ナシ止メネジ 15/64(28)×4.5	Set screw 15/64(28)×4.5	2	○	○													
73	MF 60A0 352	W461790H01	カ ラ ー	Collar for vertical shaft	1	○														
	MF 10A0 352	B 422844H01	カ ラ ー	Collar for vertical shaft	1		○													
74	MF 60A0 520	W462742H01	豎 軸	Vertical shaft	1	○														
	MF 67B0 520	W444124H01	豎 軸	Vertical shaft	1		○													
75	MF 60A0 521	W451299H01	豎 軸 メ タ ル (上)	Vertical shaft bushing (upper)	1	○														
	MG 37B0 521	W462791H01	豎 軸 メ タ ル (上)	Vertical shaft bushing (upper)	1		○													
76	M9 1606 001	B 504016H01	頭ナシ止メネジ 1/4(40)×7	Set screw 1/4(40)×7	3	○	○													
77	MF 10A0 662	W444056H01	針 ク ガ イ ド	Needle bar connecting link guide	1	○	○													
78	M9 1110 002	W500294H01	平 ネ ジ 11/64(40)×8	Screw 11/64(40)×8	2	○	○													
79	MF 10A0 325	W443934H01	角 駒	Square block	1	○	○													
80	M9 0815 002	W484210H01	平 ネ ジ 1/8(44)×4.5	Screw 1/8(44)×4.5	1	○	○													
	MF 72B0 128	S 970010H02	針 DBX1-2-21	Needle DBX1-2-21	1	○														
81	MF 23C0 128	S 970002H04	針 DBX1 #23	Needle DBX1 #23	1		○													
	MF 10A2 181	W502075H01	糸 掛	Needle bar thread guide	1	○	○													
82	MF 10A1 181	W502073H01	糸 掛	Needle bar thread guide	1	○	○													
83	M9 1102 001	W500489H01	頭ナシ止メネジ 11/64(40)×2.7	Set screw 11/64(40)×2.7	1	○	○													
84	MF 10A0 664	W450055H01	針 棒 メ タ ル (下)	Needle bar bushing (under)	1	○														
	MF 17B0 664	W457585H01	針 棒 メ タ ル (下)	Needle bar bushing (under)	1		○													
85	MF 12B0 660	W461770H01	針 棒	Needle bar	1	○														
	MF 17B0 660	W461796H01	針 棒	Needle bar	1		○													
86	MF 60A0 663	W461760H01	針 棒 メ タ ル (上)	Needle bar bushing (upper)	1	○	○													
87	M9 1503 001	B 508971H01	頭ナシ止メネジ 15/64(28)×4.5	Set screw 15/64(28)×4.5	1	○	○													
88	MF 10A2 740	W500003H01	フェルト	Felt for needle bar bushing (upper)	1	○	○													
89	MF 60A0 742	W502181H01	蓋	Cap for needle bar bushing (upper)	1	○	○													

From the library of Diamond Needle Corp.

縫目調節關係

STITCH LENGTH REGULATOR MECHANISM

DY-330

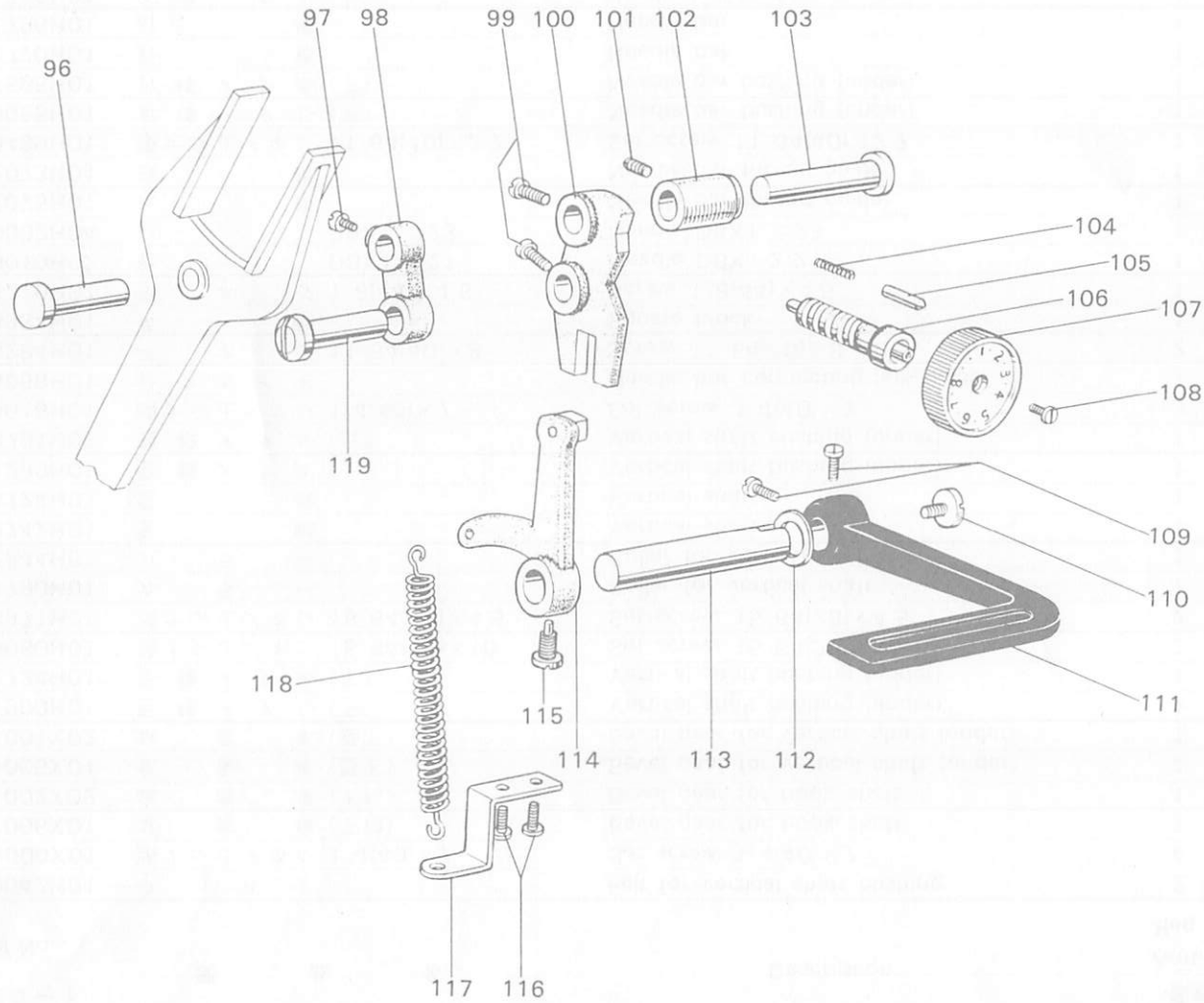

From the library of: Diamond Needle Corp

縫目調節関係

STITCH LENGTH REGULATOR MECHANISM

Fig. No.	部品コード Parts No.	資材コード Ref.No.	部 品 名	Description	使用 個数 Amt. Req.	共通部品 Common Parts														
						DY330-12	DY330-22													
96	M9 0718 063	W481425H01	段 付 軸	Set pin	1	○	○													
97	M9 1501 002	W502945H01	平 ネ ジ 15/64(28)×8.5	Screw 15/64(28)×8.5	1	○	○													
98	MF 70A0 153	W481677H01	案内テコツナギ	Feed connecting link	1	○	○													
99	M9 1504 002	B 508963H01	平 ネ ジ 15/64(28)×10	Screw 15/64(28)×10	2	○	○													
100	MF 65B0 152	W454803H01	案 内 テ コ	Feed regulator	1	○	○													
101	M9 1513 001	B 509060H01	頭ナシ止メネジ 15/64(28)×10	Set screw 15/64(28)×10	1	○	○													
102	MG 41B0 750	W479396H01	ブ ッ シ ュ	Feed connecting bushing	1	○	○													
103	M9 0904 063	W479395H01	段 付 軸	Feed connecting hinge pin	1	○	○													
104	MF 10A2 572	B 509164H01	押 エ バ ネ	Presser spring	1	○	○													
105	MF 10A0 852	B 419163H01	戻 リ 止 メ	Stopper pin	1	○	○													
106	MF 60A0 640	W452424H01	ネ ジ 棒	Stitch length regulator screw	1	○	○													
107	MG 30B0 631	W331488H01	縫目加減ツマミ	Stitch length regulator dial	1	○	○													
108	M9 1209 002	B 503887H01	平 ネ ジ 3/16(28)×6	Screw 3/16(28)×6	1	○	○													
109	M9 1501 002	W502945H01	平 ネ ジ 15/64(28)×8.5	Screw 15/64(28)×8.5	2	○	○													
110	M9 1207 003	B 509288H01	丸 平 ネ ジ 3/16(28)×6.5	Screw 3/16(28)×6.5	1	○	○													
112	M9 5003 053	B 503895H01	バ ネ 座 金	Spring washer	1	○	○													
113	MF 60A0 633	W462608H01	縫 目 加 減 軸	Reverse stitch lever shaft	1	○	○													
114	MG 41E0 635	W331018G01	縫 目 加 減 腕 (組)	Stitch length regulating bracket complete	1	○	○													
115	M9 1501 007	B 509256H01	棒先止メネジ 15/64(28)×14.5	Screw 15/ 64(28)×14.5	1	○	○													
116	M9 1110 002	W500294H01	平 ネ ジ 11/64(40)×8	Screw 11/64(40)×8	2	○	○													
117	MG 30B0 708	W462888H01	バ ネ 止 メ 板	Feed regulating spring holder	1	○	○													
118	MF 60A0 572	W445312H01	ツル 巻 バ ネ	Spring	1	○	○													
119	M9 0905 063	W501377H01	段 付 ピ ン φ9×27	Set pin φ9×27	1	○	○													

From the library of: Jia men Needle Corp

押工関係

PRESSER FOOT MECHANISM

DY-330

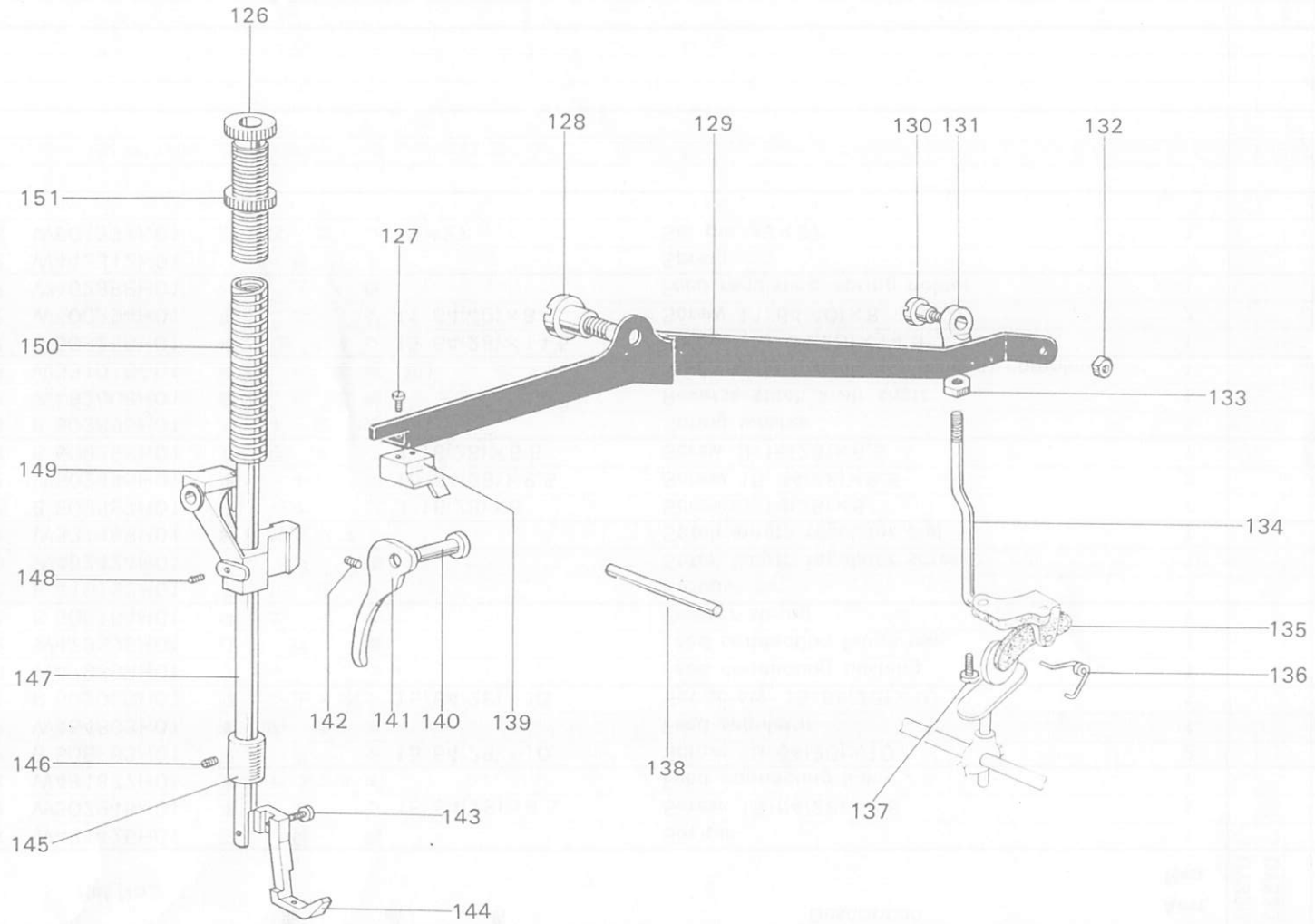

From the library of: Diamond Needle Corp

押エ関係

PRESSER FOOT MECHANISM

Fig. No.	部品コード Parts No.	資材コード Ref.No.	部 品 名	Description	使用 個数 Amt. Req.	共通部品 Common Parts														
						DY330-12	DY330-22													
126	M9 3201 035	B 409037H01	押エ調節ネジ 1/2(28)×43	Presser regulating thumb screw	1	○	○													
127	M9 1110 002	W500294H01	平ネジ 11/64(40)×8	Screw 11/64(40)×8	2	○	○													
128	M9 1601 016	W501020H01	段付丸平ネジ 1/4(24)×14	Hinged screw 1/4(40)×14	1	○	○													
129	MG 30E0 725	W484822G01	膝上ゲレバー(上)	Lifting lever	1	○	○													
130	M9 1505 016	B 509176H01	段付丸平ネジ 15/64(28)×10	Hinged screw 15/64(28)×10	1	○	○													
131	MF 60A0 591	W462748H01	テコ接手	Knee lifter rock shaft arm	1	○	○													
132	M9 1501 045	B 509260H01	ナット 15/64(28)	Nut 15/64(28)	1	○	○													
133	M9 1251 045	W509177H01	ナット 3/16(32)	Nut 3/16(32)	1	○	○													
134	MG 30B0 593	W461082H01	テコ引棒	Lifting lever connecting rod	1	○	○													
135	MG 30E0 594	W482314G01	テコ引仕掛(組)	Knee lifter bell crank complete	1	○	○													
136	MG 30B1 729	W464022H02	ヒネリバネ	Knee lifter bell crank spring	1	○	○													
137	M9 1104 003	B 509264H01	丸平ネジ 11/64(40)×12	Screw 11/64(40)×12	2	○	○													
138	M9 0414 060	W502957H03	糸ユルメピン φ4×44	Upper thread releasing pin	1	○	○													
139	MG 30B0 222	W482313H01	糸ユルメカム	Upper thread releasing cam	1	○	○													
140	M9 0704 063	B 503977H01	押エ上ゲピン	Presser foot lifting pin	1	○	○													
141	MF 60A0 252	W443698H01	押エ上ゲ	Presser lifter	1	○	○													
142	M9 1109 001	W500985H01	頭ナシ止メネジ 11/64(40)×6.6	Set screw 11/64(40)×6.6	1	○	○													
143	M9 0922 002	W464016H01	平ネジ 9/64(40)×8	Screw 9/64(40)×8	1	○	○													
144	MG 10B0 256	W464028H01	押エ足	Presser foot (inside)	1	○	○													
145	MG 30B0 267	W462887H01	押エ棒メタル(下)	Presser bar bushing (under)	1	○	○													
146	M9 1102 001	W500489H01	頭ナシ止メネジ 11/64(40)×2.7	Screw 11/64(40)×2.7	2	○	○													
147	MF 60A0 262	W444011H01	押エ棒	Presser bar	1	○	○													
148	M9 1508 001	B 509088H01	頭ナシ止メネジ 15/64(28)×8	Set screw 15/64(28)×8	1	○	○													
149	MG 30E0 265	W482311G01	押エ棒ダキ	Presser bar holder	1	○	○													
150	MF 60A0 259	W443638H01	押エバネ	Presser bar spring	1	○	○													
151	M9 3201 045	W471438H01	特殊ナット 1/2(28)	Special nut 1/2(28)	1	○	○													

From the library of Diamond Needle Corp.

上部送り関係

UPPER FEED MECHANISM

DY-330

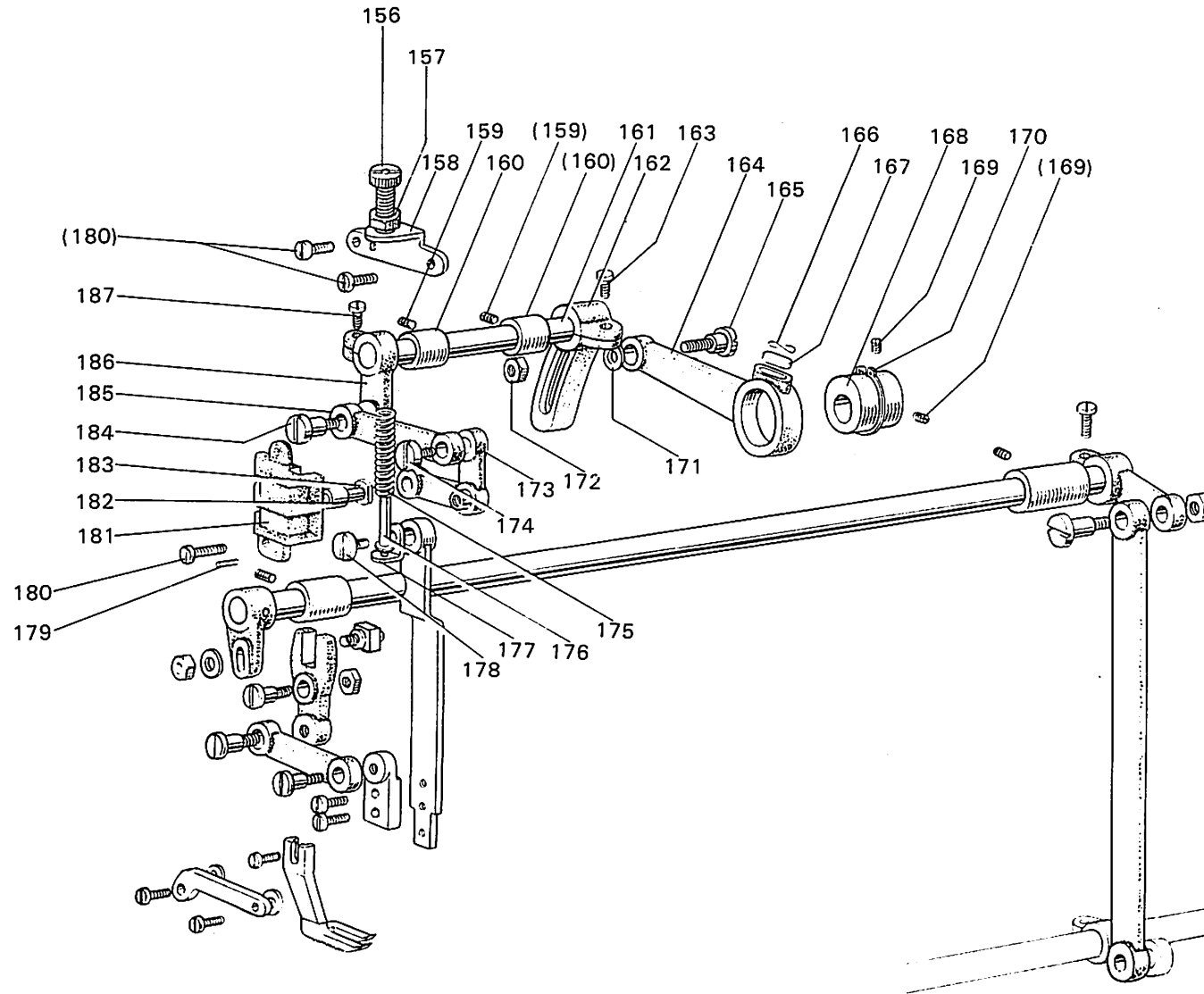

From the library of: Diamond Needle Corp

上部送り関係

UPPER FEED MECHANISM

Fig. No.	部品コード Parts No.	資材コード Ref.No.	部 品 名	Description	使用 個数 Amt. Req.	共通部品 Common Parts															
						DY330-12	DY330-22														
156	M9 1801 035	W502411H01	調節ネジ 9/32(28)×35	Feed regulating screw	1	○	○														
157	M9 1801 045	W500009H01	ナット 9/32(28)	Nut 9/32(28)	1	○	○														
158	MG 30B1 261	W480473H01	押エ調節台	Presser regulating bracket	1	○	○														
159	M9 1108 001	B 503846H01	頭ナシ止メネジ 11/64(40)×5.5	Set screw 11/64(40)×5.5	2	○	○														
160	MG 10B0 833	W502463H01	送り軸メタル(上部上下)	Feed lifting rock shaft bushing	2	○	○														
161	MG 10B0 460	W502418H01	上部上下軸	Feed lifting rock shaft	1	○	○														
162	MG 30B0 463	W454865H02	上部上下送り腕(右)	Feed lifting rock shaft crank (right)	1	○	○														
163	M9 1603 003	W501009H01	丸平ネジ 1/4(24)×16	Screw 1/4(24)×16	1	○	○														
164	MG 30B0 384	W480485H01	クランクロッド(接続桿)	Feed connecting crank rod	1	○	○														
165	M9 1551 015	W480471H02	段付平ネジ M6 P0.75×24	Hinged screw M6 P0.75×24	1	○	○														
166	MF 60A0 700	W500836H01	バネ	Spring for felt stopper	1	○	○														
167	MF 60A1 740	W500738H01	フェルト	Felt for feed connecting crank rod	1	○	○														
168	MG 30B0 760	W480462H01	偏心輪	Feed lifting eccentric	1	○	○														
169	M9 1606 001	B 504016H01	頭ナシ止メネジ 1/4(40)×7	Set screw 1/4(40)×7	2	○	○														
170	M9 0325 065	S 591411H05	C形止メ輪(偏心輪) 25	C-type stop ring 25	1	○	○														
171	M9 0607 050	S 562131H04	ミガキ座金 6	Washer 6	1	○	○														
172	M9 1572 045	S 542112H01	Uナット M6×0.75	U-nut 6×0.75	1	○	○														
173	MG 30B0 763	W481609H01	ベルクランク	Bell crank	1	○	○														
174	M9 1681 015	W480472H01	段付平ネジ 1/4(40)×12	Hinged screw 1/4(40)×12	1	○	○														
175	MG 41B1 572	W481636H01	押エバネ	Spring	1	○	○														
176	MG 30B0 732	W464020G01	ピン案内金(組)	Spring guide bar complete	1	○	○														
177	MG 30B0 226	W461057H01	押エ板支エ(受金)	Prop up washer	1	○	○														
178	M9 1210 002	W501247H01	平ネジ 3/16(28)×10	Screw 3/16(28)×10	1	○	○														
179	M9 0315 060	B 509137H02	ピン 3.2×9	Set pin 3.2×9	2	○	○														
180	M9 1110 002	W500294H01	平ネジ 11/64(40)×8	Screw 11/64(40)×8	4	○	○														
181	MG 30B1 765	W480467H01	ベルクランクガイド	Bell crank guide bracket	1	○	○														
182	MG 10B0 411	W501534H01	コ ロ	Bell crank guide bracket block	1	○	○														
183	M9 0507 063	W502457H01	コ ロ 軸(支エ軸)	Bell crank guide pin	1	○	○														
184	M9 1681 015	W480472H01	段付平ネジ 1/4(40)×12	Hinged screw 1/4(40)×12	1	○	○														
185	MG 10B0 910	W457552H01	リンク(連続桿)	Feed lifting rock shaft link	1	○	○														
186	MG 30B0 462	W461063H02	上部上下送り腕(左)	Upper feed lifting rock shaft crank	1	○	○														
187	M9 1506 002	W502152H01	平ネジ 15/64(28)×14	Screw 15/64(40)×14	1	○	○														

From the library of: Diamond Needle Corp.

上部送り関係

UPPER FEED MECHANISM

DY-330

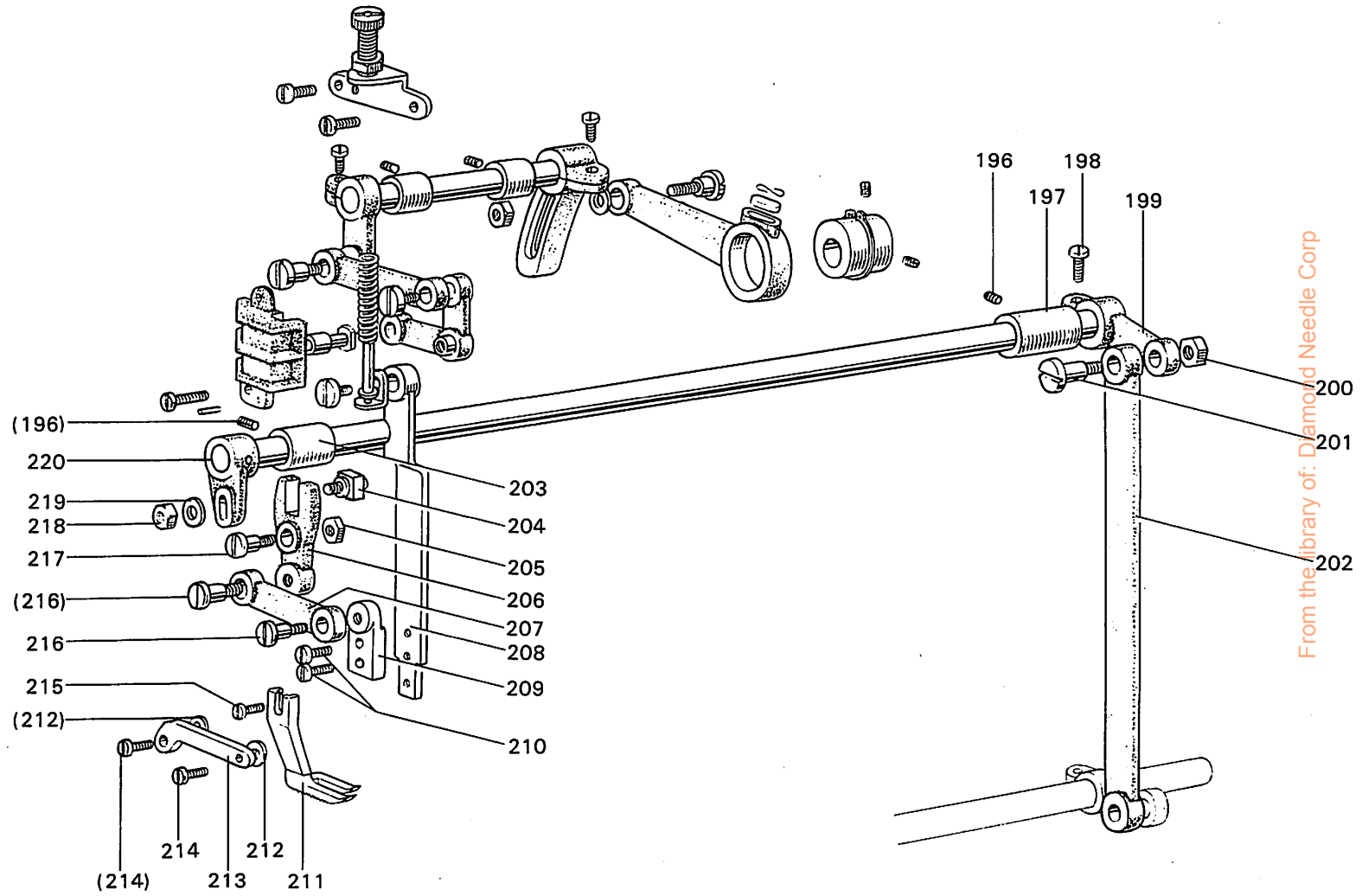

上部送り関係

UPPER FEED MECHANISM

Fig. No.	部品コード Parts.No.	資材コード Ref.No.	部 品 名	Description	使用 個数 Amt. Req.	共通部品 Common Parts														
						DY330-12	DY330-22													
196	M9 1108 001	B 503846H01	頭ナシ止メネジ 11/64(40)×5.5	Set screw 11/64(40)×5.5	2	○	○													
197	MG 30B0 287	W466249H01	上部水平送り軸メタル (右)	Feed driving shaft bushing (right)	1	○	○													
198	M9 1603 003	W501009H01	丸 平 ネ ジ 1/4(24)×16	Screw 1/4(24)×16	1	○	○													
199	MG 30E0 465	W462666H01	上部水平送り腕 (右)	Feed driving rock shaft crank	1	○	○													
200	M9 1802 045	B 508961H01	ナ ッ ト 9/32(28)	Nut 9/32(28)	1	○	○													
201	M9 1803 015	W454870H01	段 付 平 ネ ジ 9/32(28)×26.1	Connecting rod hinge screw	1	○	○													
202	MG 30B0 954	W324564H01	連 結 リ ン グ	Feed drive connecting link	1	○	○													
203	MG 30B0 285	W457554H01	上部水平送り軸メタル (左)	Feed driving shaft bushing (left)	1	○	○													
204	MG 30E0 410	W443980H01	コ ロ ・ コ ロ 軸 (組) (W464052H01)	Feed connecting slick brock complete	1	○	○													
205	M9 1620 045	W482843H01	ナ ッ ト 1/4(24)	Nut 1/4(24)	1	○	○													
206	MG 30B1 950	W480465H01	変 換 レ バ ー	Feed connecting rod lever	1	○	○													
207	MG 10B0 910	W457552H01	リ ン ク (連接桿)	Walking foot connecting link	1	○	○													
208	MG 30B0 295	W461085H01	送 り 足 支 エ	Walking foot guide link	1	○	○													
209	MG 30B2 273	W480470H02	送 り 腕 (取付金)	Feed arm	1	○	○													
210	M9 0910 003	B 509270H01	丸 平 ネ ジ 9/64(40)×7	Screw 9/64(40)×7	2	○	○													
211	MG 10B0 294	W321338H01	送 り 足	Walking foot	1	○	○													
212	M9 0414 050	W480469H01	座 金	Washer	2	○	○													
213	MG 30B1 296	W480468H01	送り足支エ案内	Walking foot guide bracket	1	○	○													
214	M9 1112 002	W501889H01	平 ネ ジ 11/64(40)×12	Screw 11/64(40)×12	2	○	○													
215	M9 0922 002	W464016H01	平 ネ ジ 9/64(40)×8	Walking foot set screw 9/64(40)×8	1	○	○													
216	M9 1681 015	W480472H01	段 付 平 ネ ジ 1/4(40)×12	Hinged screw 1/4(40)×12	2	○	○													
217	M9 1683 015	W480472H03	段 付 平 ネ ジ 1/4(40)×25	Hinged screw 1/4(40)×25	1	○	○													
218	M9 1601 045	W501989H01	ナ ッ ト 1/4(24)	Nut 1/4(24)	1	○	○													
219	M9 0617 050	S 562111H01	座 金	Washer	1	○	○													
220	MG 30E0 464	W464030G01	上部水平送り腕 (送り軸付) (組)	Feed driving rock shaft crank complete	1	○	○													

From the library of Diamond Needle Corp

送り関係

LOWER FEED MECHANISM

DY-330

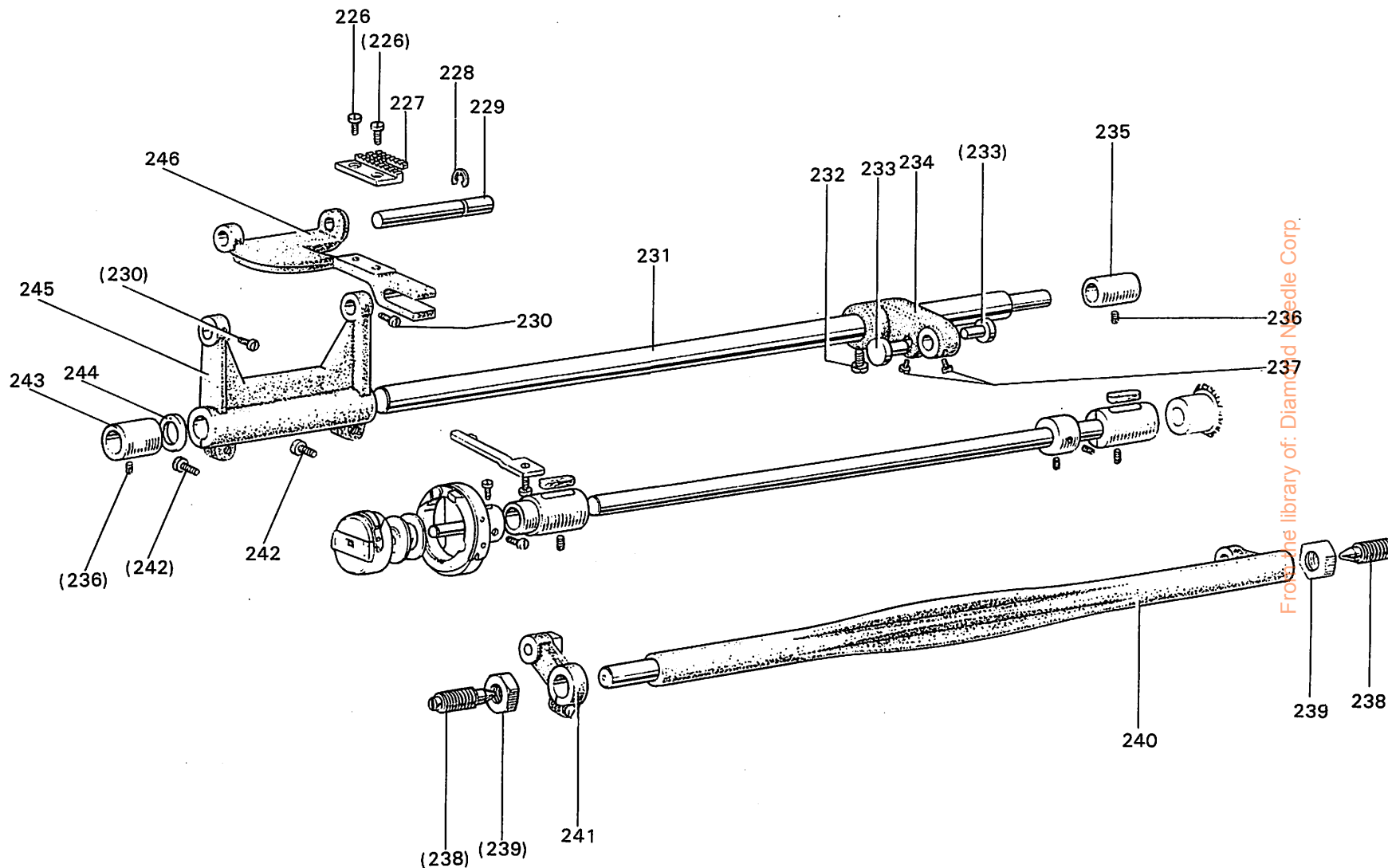

From the library of: Diamond Needle Corp.

送り関係

LOWER FEED MECHANISM

Fig. No.	部品コード Parts.No.	資材コード Ref.No.	部 品 名	Description	使用 個数 Amt. Req.	共通部品 Common Parts													
						DY330-12	DY330-22												
226	M9 0806 002	B 508857H01	平ネジ 1/8(44)×6	Screw 1/8(44)×6	2	○	○												
227	MF 10A0 104	W462604H01	送り	Feed dog	1	○	○												
228	M9 0505 065	S 592411H05	E形止メ輪	E-type stop ring	1	○	○												
229	MF 20A0 283	W470281H01	送り台支エ軸	Feed bar holder stud	1	○	○												
230	M9 1110 002	W500294H01	平ネジ 11/64(40)×8	Screw 11/64(40)×8	2	○	○												
231	MF 65B0 491	W454811H01	水平送り軸	Feed rock shaft	1	○	○												
232	M9 1603 003	W501009H01	丸平ネジ 1/4(24)×16	Screw 1/4(24)×16	1	○	○												
233	M9 0904 060	W502476H02	ピン	Pin for feed lifting rock shaft crank	1	○	○												
234	MG 30B0 306	W480463H01	送り駆動腕	Feed lifting & rock shaft crank	1	○	○												
235	MF 10A0 287	W446173H01	送り軸メタル(右)	Feed rock shaft bushing (right)	1	○	○												
236	M9 1513 001	B 509060H01	頭ナシ止メネジ 15/64(28)×10	Set screw 15/64(28)×10	1	○	○												
237	M9 1501 002	W502945H01	平ネジ 15/64(28)×8.5	Screw 15/64(28)×8.5	2	○	○												
238	M9 2403 034	W464015H01	センターネジ 3/8(28)×35	Feed lifting rock shaft screw 3/8(28)×35	1	○	○												
239	M9 2402 045	B 509118H01	ナット 3/8(28)	Nut 3/8(28)	1	○	○												
240	MF 60A0 460	W321790H01	上下送り軸	Feed lifting rock shaft	1	○	○												
241	MF 60E0 276	W462749G01	上下送り腕(組)	Feed lifting rock shaft crank (left) complete	1	○	○												
242	M9 1203 002	B 509178H01	平ネジ 3/16(28)×15	Screw 3/16(28)×15	2	○	○												
243	MF 10A0 286	W454875H01	送り軸メタル(左)	Feed rock shaft bushing (left)	1	○	○												
244	M9 3001 052	W502467H01	特殊座金	Feed rock shaft bushing washer	1	○	○												
245	MF 65B0 278	W454810H01	水平送り腕(左)	Feed rock shaft crank (left)	1	○	○												
246	MF 10A0 281	W447752H01	送り台	Feed bar	1	○	○												

From the library of: Diamond Needle Corp

下軸・カマ関係

HOOK SHAFT & ROTATING HOOK MECHANISM

DY-330

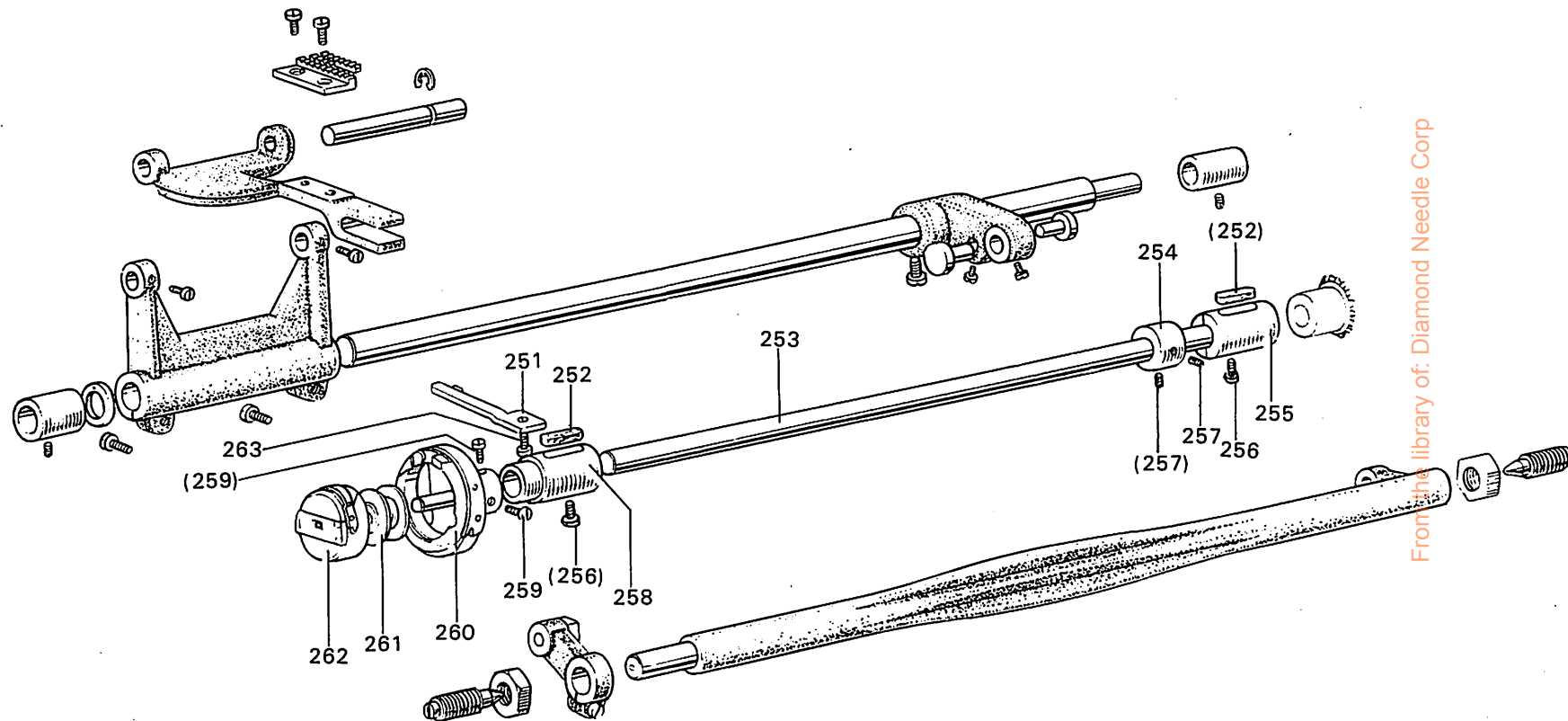

From the library of: Diamond Needle Corp

下軸・カマ関係

HOOK SHAFT & ROTATING HOOK MECHANISM

Fig. No.	部品コード Parts. No.	資材コード Ref.No.	部 品 名	Description	使用 個数 Amt. Req.	共通部品 Common Parts														
						DY330-12	DY330-22													
251	MF 10A0 229	W462633H01	内ガマ止メ	Rotating hook holder	1	○														
	MF 20A0 229	W468837H01	内ガマ止メ	Rotating hook holder	1		○													
252	MF 60A0 740	W500042H01	フェルト	Felt	2	○	○													
253	MF 60A0 450	W452367H01	下軸	Rotating hook shaft	1	○														
	MF 67C0 450	W475480H01	下軸	Rotating hook shaft	1		○													
254	MF 60A0 352	W461790H01	カラ	Rotating hook shaft collar	1	○	○													
255	MF 60A0 452	W450514H01	下軸メタル(右)	Rotating hook shaft bushing (right)	1	○														
	MF 37B0 452	W462738H01	下軸メタル(右)	Rotating hook shaft bushing (right)	1		○													
256	M9 1117 002	B 503844H01	平ネジ 11/64(40)×13	Screw 11/64(40)×13	2	○	○													
257	M9 1503 001	B 508971H01	頭ナシ止メネジ 15/64(28)×4.5	Set screw 15/64(28)×4.5	2	○	○													
258	MF 60A0 451	W450513H01	下軸メタル(左)	Rotating hook shaft bushing (left)	1	○														
	MF 67B0 451	W462735H01	下軸メタル(左)	Rotating hook shaft bushing (left)	1		○													
259	M9 1103 002	B 509062H01	平ネジ 11/64(40)×5	Screw 11/64(40)×5	3	○	○													
260	MF 62B0 120	W469135H01	カマ KR21-R(組)	Rotating hook complete KR21-R	1	○														
	MF 25B0 120	P 975005X02	カマ KH-20RM2(組)	Rotating hook complete KH-20RM2	1		○													
261	MF 10A0 123	W462632H01	ボビン	Bobbin	1	○														
	MF 25B0 123	W470215H01	ボビン	Bobbin	1		○													
262	MF 10E0 125	W461742G01	ボビンケース(組)	Bobbin case complete	1	○														
	MF 25E0 125	W473391H01	ボビンケース(組)	Bobbin case complete	1		○													
263	M9 1118 002	B 509061H01	平ネジ 11/64(40)×10	Screw 11/64(40)×10	1	○	○													

From the library of Diamond Needle Corp

49 49

給油関係

OIL LUBRICATION MECHANISM

DY-330

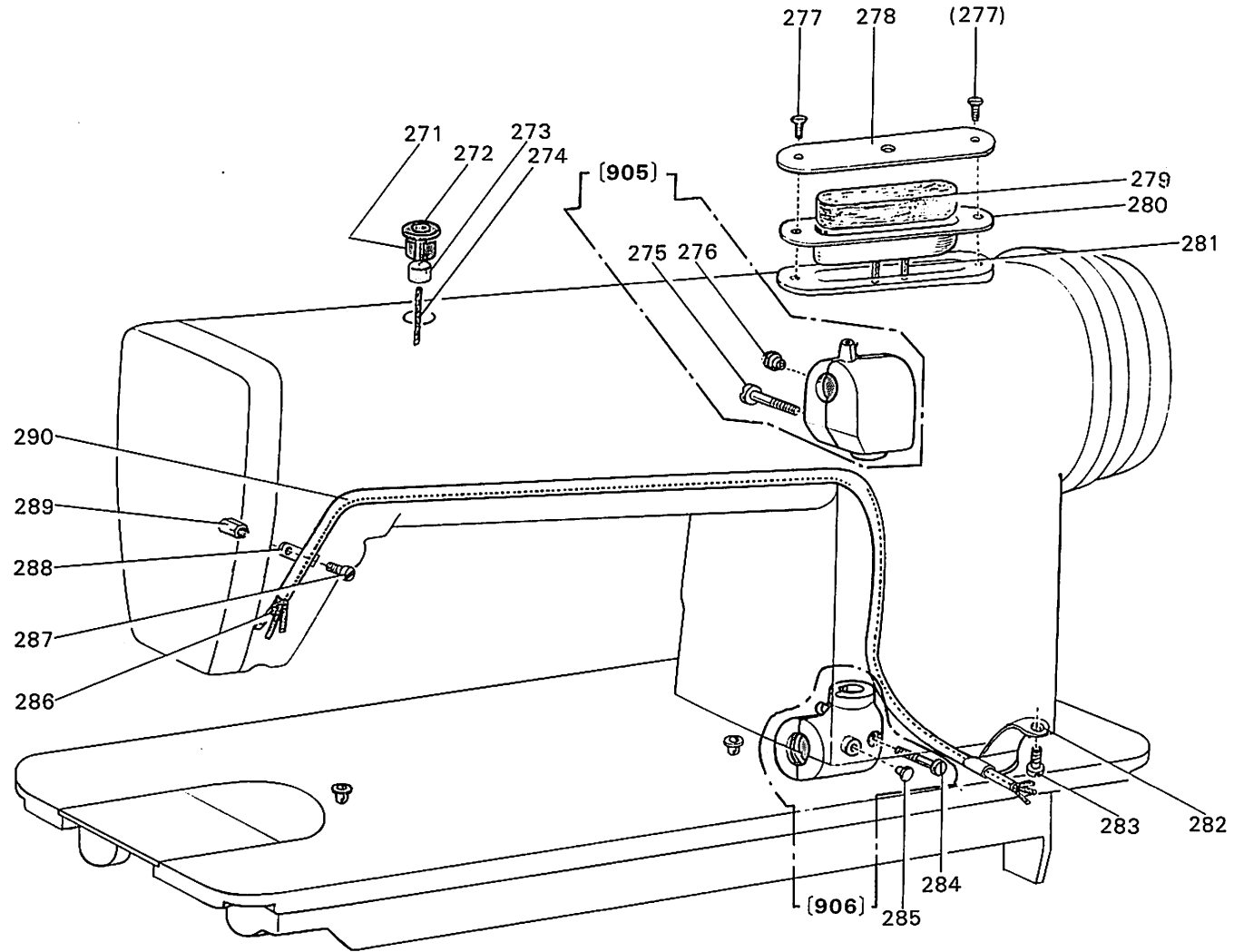

From the library of: Diamond Needle Corp

給油関係

OIL LUBRICATION MECHANISM

Fig. No.	部品コード Parts. No.	資材コード Ref.No.	部 品 名	Description	使用 個数 Amt. Req.	共通部品 Common Parts														
						DY330-12	DY330-22													
271	MG 30B0 688	W471447H01	パイプ (油蓋)	Pip for Oiler	1	○	○													
272	MG 41B0 742	W471448H01	油蓋	Cap for oiler	1	○	○													
273	MF 60A5 740	W500906H01	フェルト	Felt for oiler	1	○	○													
274	MF 10E2 148	W464023H01	油紐 φ2.5×35	Oil wick φ2.5×35	1	○	○													
275	M9 0501 037	S 512131H41	平ネジ M5×12	Screw M5×12	1	○	○													
276	M9 0570 080	W502078H01	ゴム栓	Rubber plug	2	○	○													
905	MG 30E0 711	W484213G01	歯車箱上 (組)	Arm shaft bevel gear box complete (upper)	1	○	○													
277	M9 0920 002	W501523H01	平ネジ 9/64(40)×6.5	Screw 9/64(40)×6.5	2	○	○													
278	MF 60A0 134	W445619H01	油蓋 (右)(油タンク)	Oil resarvoir cover (right)	1	○	○													
279	MF 60A4 740	W500905H01	フェルト	Felt for oil resarvoir	1	○	○													
280	MF 60A0 139	W447200H03	油タンク (右)	Oil resarvoir (right)	1	○	○													
281	MF 10E2 148	W464039H01	油紐 φ2.5×100	Oil wick φ2.5×100	1	○	○													
282	MF 65B0 690	W501200H01	管押エ	Oil pipe holder	1	○	○													
283	M9 0920 002	W501523H01	平ネジ 9/64(40)×6.5	Screw 9/64(40)×6.5	1	○	○													
284	M9 0502 037	S 512131H19	平ネジ M5×10	Screw M5×10	1	○	○													
906	MG 41E0 712	W481406G01	歯車箱下 (組)	Hook shaft bevel gear box complete (under)	1	○	○													
286		W464027H01	毛糸	Wool yarn	1	○	○													
287	M9 1104 003	B 509264H01	丸平ネジ 11/64(40)×12	Screw 11/64(40)×12	1	○	○													
288	MF 10A0 689	W444230H01	パイプホルダー	Pipe holder	1	○	○													
289	M9 1102 045	W501097H01	ナット 11/64(40)	Pipe holder nut	1	○	○													
290	MG 10B0 731	W464026H01	ビニールパイプ	Oil pipe	1	○	○													

From the library of: Diamond Needle Corp

付属品箱関係

ACCESSORY BOX & ACCESSORIES

DA-330

DY-330

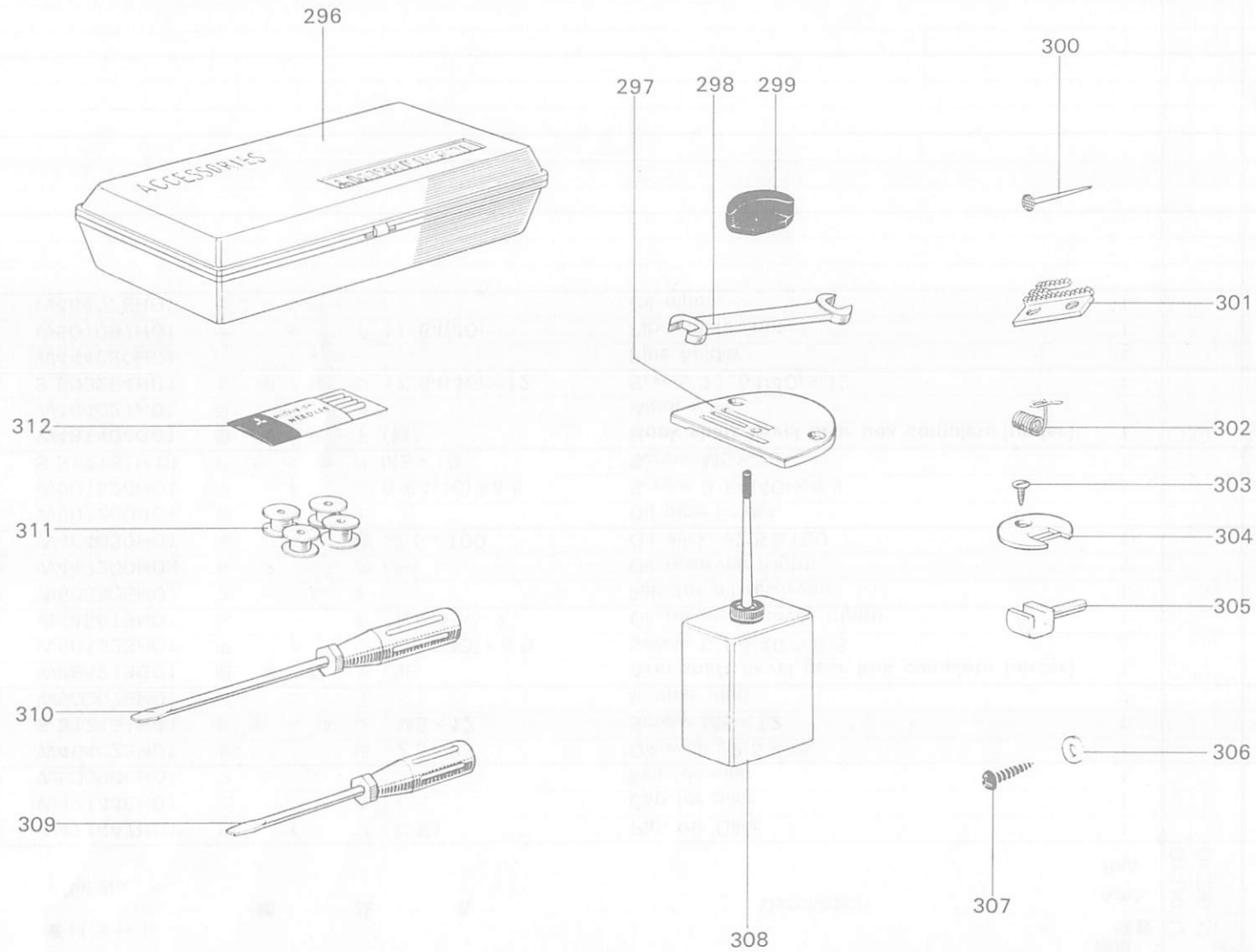

From the library of: Diamond Needle Corp

付属品箱関係

ACCESSORY BOX & ACCESSORIES

Fig. No.	部品コード Parts. No.	資材コード Ref.No.	部 品 名	Description	使用 個数 Amt. Req.	共通部品 Common Parts															
						DY330-12	DY330-22														
296	MF 60A0 749	P 833000X01	付 属 品 箱	Accessry box	1	○	○														
297	MF 26B0 101	W322721H01	(輸出専用)	Needle plate (B-2.6)	1	○	○														
298	MM 10A1 479	B 422776H01	ス パ ナ	Spanner	1	○	○														
299	MF 60A0 419	W449461H01	防 振 ゴ ム	Vibration preventing rubber	4	○	○														
300		S 817001H12	釘 N25	Nail N25	10	○	○														
301	MF 10A0 104	W462604H01	(輸出専用)	Feed dog	1	○	○														
302	MF 12B0 187	W461748H01	糸 取 リ バ ネ	Thread take-up spring	1	○	○														
303	M9 0601 040	S 519131H06	皿 木 ネ ジ 6.2×25	Screw 6.5×25	2	○	○														
304	MF 60A0 560	W502125H01	(輸出専用)	Hinge	2	○	○														
305	MF 60A0 562	W502124H01	蝶 番	Hing rod	2	○	○														
306	M9 0607 050	S 562131H04	ミ ガ キ 座 金 6	Washer 6	2	○	○														
307	M9 0401 041	S 519132H01	丸 木 ネ ジ 4.5×20	Screw 4.5×20	2	○	○														
308	MF 60A 0 137	P 831001X01	油 差 シ	Oil with oiler	1	○	○														
309	MB 02A1 608	P 842002X01	ド ラ イ バ ー (小)	Screw driver (small)	1	○	○														
310	MB 02A0 608	P 842003X01	ド ラ イ バ ー (中)	Screw driver (middle)	1	○	○														
311	MF 10A0 123	W462632H01	ボ ビ ン	Bobbin	4	○															
	MF 25B0 123	W470215H01	ボ ビ ン	Bobbin	1	○	○														
312	MF 72B0 128	S 970010H02	針 DB×1-2-21 (国内専用)		4	○	○														
	MF 23C0 128	S 970002H04	(輸出専用)	Needle DB×1 #23	4	○	○														

From the library of: Diamond Needle Corp

付属品関係

OIL PAN & OTHER ACCESSORIES

DY-330

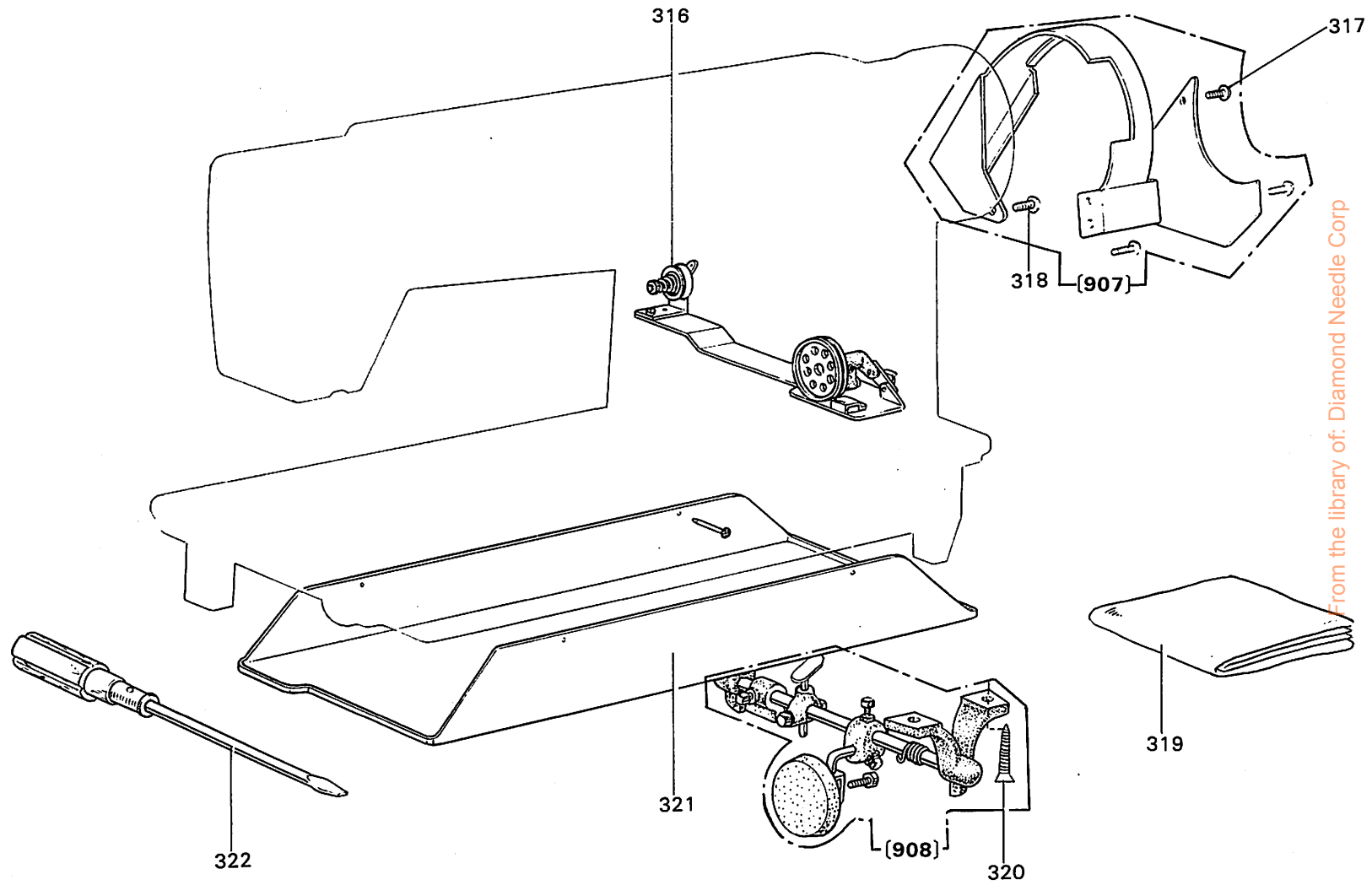

From the library of: Diamond Needle Corp

付属品関係

OIL PAN & OTHER ACCESSORIES

Fig. No.	部品コード Parts.No.	資材コード Ref.No.	部 品 名	Description	使用 個数 Amt. Req.	共通部品		Common Parts										
						DY330-12	DY330-22											
316	MF 20E0 190	P 992002X01	糸 巻 仕 掛	Bobbin winder complete	1	○												
	MF 67E0 190	P 992004X01	糸 巻 仕 掛	Bobbin winder complete	1	○												
317	M9 1101 004	W466810H01	フ ラ マ イ ネ ジ 11/64(40)×8	Screw 11/64(40)×8	3	○	○											
907	MF 20E0 776	W341683G01	ベルトカバー(組) (国内専用)		1	○												
	MF 67E0 776	W341683G09	ベルトカバー(組) (国内専用)		1		○											
318	M9 1103 004	W467868H02	フ ラ マ イ ネ ジ 11/64(40)×13	Screw 11/64(40)×13	3	○	○											
319	MF 60A0 734	W220627H02	ビニールカバー	Vinyl covor	1	○												
320	M9 0401 040	S 519131H04		(輸出専用) Screw 4.5×32	4	○	○											
908	MF 60E1 727	ZM000099		(輸出専用) Knee lifter complete	1	○	○											
321	MF 60A0 131	B 309125H01	油 受 ケ	Oil pan	1	○	○											
322	MF 60A0 608	W319408H01	ド ラ イ バ ー (大)	Screw drive (large)	1	○	○											

From the library of: Diamond Needle Corp.

MEMO

A series of horizontal dotted lines for writing.

From the library of Diamond Needle Corp



MEMO

From the library of: Diamond Needle Corp

MEMO



From the library of: Diamond Needle Corp